



承 认 书

APPROVAL SHEET

客 户:

CUSTOMER: _____

品 名:

PARTNAME: 铝电解电容器(E-CAP)

系 列:

SERIES: CD289Y (LY 低阻抗值 Low impedance) 系列

规 格:



SPECIFICATION: 见尺寸表

版本号:

VERSION: QWH-17.001

日 期:

DATE: 2017.11.20

制 造 MANUFACTURE		客 户 CUSTOMER	
拟 制 FORMULATE	批 准 APPROVAL	检 验 CHECK	批 准 APPROVAL
 			



序号 No	目 录 INDEX	页 page
1	概述 SCOPE	4
2	订货方式 HOW TO ORDER	4
3	主要特性表 MAIN SPECIFICATIONS	5
4	产品结构 PRODUCT STRUCTURE	6
5	纹波电流频率因子 RIPPLE CURRENT FREQUENCY COEFFICIENT	8
6	尺寸表、允许纹波电流 DIMENSIONS AND RIPPLE CURRENT	9
7	包装 PACKING	12
8	贮存方法 STORAGE METHODS	12
9	其他说明 OTHERS	13



1. 概述 SCOPE

1.1 概述 SCOPE

本承认书规定了铝电解电容器的技术规范。

This specification contains descriptions of the quality of aluminum electrolytic capacitors.

1.2 参考标准 APPLICABLE SPECIFICATION

本承认书参考 JISC-5141 和 JISC-5102 制定。

This specification is made based on the Japanese Industrial Standard JISC-5141 Characteristics and JIS C-5102.

1.3 工作温度范围 OPERATING TEMPERATURE RANGE

工作温度范围是电容器在施加额定工作电压条件下，可以长期可靠工作的环境温度范围。

Operating temperature range is the range of ambient temperature at which the capacitor can be operated continuously at rated voltage.

2. 订货方式 HOW TO ORDER

2.1 订货方式 HOW TO ORDER

① ② ③ ④ ⑤ ⑥ ⑦ ⑧ ⑨ ⑩
8 102 LD M 1020 LY N 0 11 0

代码 Code	产品类别 Type
8	成品 Product
1	素子 Element
2	裸品 Semifinished Product

代码 Code	电压 Voltage
LA	6.3
LB	10
LC	16
LD	25
LE	35
LF	50
LG	63
LH	80
MA	100
MB	160
MC	200
MJ	220
MD	250
MF	350
VA	400
VB	450
VC	500

代码 Code	尺寸 Dimensions ΦDxL(mm)
0511	Φ5x11
AA12	Φ6.3x12
0812	Φ8x12
1020	Φ10x20
AB20	Φ12.5x20

代码 Code	商标 Trademark
N	LH.NOVA

代码 Code	内码 Internal Code
11	105℃ 普通品 105℃ regular
15	105℃ 凸台胶粒 105℃ convex rubber
1E	105℃ 普通品 PET 胶管 105℃ regular & PET Sleeve
1F	105℃ 凸台胶粒 PET 胶管 105℃ convex rubber & PET Sleeve

代码 Code	标称容量 Nominal Capacitance
R22	0.22uF
1R0	1uF
2R2	2.2uF
220	22uF
221	220uF
222	2200uF
223	22000uF

代码 Code	误差 Tolerance
J	± 5%
K	± 10%
V	± ²⁰ ₁₀ %
M	± 20%
Q	± ³⁰ ₁₀ %
T	± ⁵⁰ ₁₀ %
A	特殊

代码 Code	型号 Series
LY	CD289Y

代码 Code	产品脚型 Lead Forming Type
0	散装品 Bulk
T	5mm 贴片编带品 5mm Chip tape
A	(Φ4-Φ6.3)2.5mm 脚距编带品; 2.5mm Tape
F	(Φ4-Φ8)5mm 脚距编带品; 5mm Tape
P	直径Φ≥Φ8mm 直脚方式编带品 original type(vertical) tape
M	5mm 成型剪脚品 5mm Lead forming
C	原脚距型成型剪脚品 C Lead forming
B	B 型成型剪脚品 B Lead forming
D	(Φ4-Φ5)2.5mm 成型剪脚品 Lead forming

代码 Code	胶管颜色 Sleeve Color
0	黑色 Black
1	深蓝色 Deep-blue
4	紫色 Purple
5	墨绿色 Black-green
7	棕色 Brown
9	绿色 Green



2.2 标记 MARKING

2.2.1 在电容器上应注明如下内容 The following items shall be marked indelibly on the surface of capacitor:

- (1) 生产厂商商标 Manufacturer's name or trade mark. →
- (2) 电容量 Capacitance. →
- (3) 工作电压 Rated voltage. →
- (4) 负极标志 Polarity of the terminals. →

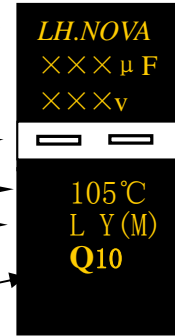

- (5) 上限工作温度 Maximum operating temperature. 示例 Sample: 105°C →
- (6) 系列代码及容量偏差代码 Series Code & Capacitance tolerance Code →

示例 Sample: LY (M)
系列代码 容量偏差代码

- (7) 生产日期 Produce date 示例 Sample: Q 10
YEAR MONTH

I、年份代码表示原则: YEAR CODE:

年份 Year	2001	2002	2003	2004	...	2017	...	2026	2027	2028	...	2052
代码 Code	A	B	C	D		Q		Z	A	B		Z

II、月份代码表示原则: MONTH CODE:

月份 Month	1 月份	4 月份	7 月份	10 月份
代码 Code	01	04	07	10

(8) PVC 胶管 PVC SLEEVE

2.2.2 标记颜色 Marking color

套管颜色 Sleeve color: 黑色 Black.

标记颜色 Marking color: 绿金色 Golden-Green.

3. 主要特性表 MAIN SPECIFICATIONS

项目 Item	主要特性 Performance Characteristics	
额定工作电压范围 Rated Voltage Range	6.3~100V.DC	
使用温度范围 Operating Temperature Range	-55°C~+105°C	
标称静电容量范围 Nominal Capacitance Range	0.47~18000 μF	
静电容量允许偏差 Capacitance Tolerance	$\pm 20\%$ (M, +20°C, 120Hz)	
漏电流 Leakage Current (20°C)	额定工作电压(V) Rated working voltage	6.3~100
	漏电流 Leakage current	2 分钟后 $I \leq 0.01\text{CV}$ 或 $3(\mu\text{A})$, 取最大值 After 2 min. $I \leq 0.01\text{CV}$ or $3(\mu\text{A})$, Whichever is greater.
损耗角正切 DF Dissipation Factor	额定工作电压(V) Rated working voltage	6.3 10 16 25 35 50 63 80 100
	DF(MAX) (20°C, 120Hz)	0.18 0.16 0.14 0.12 0.12 0.10 0.09 0.09 0.08
当容量值大于 1000 μF 时, 每增加 1000 μF , DF 值加 0.02 For capacitance of more than 1000 μF , add 0.02 for every increase of 1000 μF .		



项目 Item	主要特性 Performance Characteristics																									
浪涌电压 Surge Voltage	额定工作电压(V) Rated working voltage		6.3	10	16	25	35	50	63	80	100															
	浪涌电压(V) Surge voltage		8	13	20	32	44	63	79	100	125															
温度特性 Temperature Stability	额定工作电压(V) Rated working voltage					6.3	10	16	25~100																	
	阻抗比(120Hz) Impedance Ratio		z-25°C/z+20°C		4	3	2	2																		
		z-55°C/z+20°C		8	6	4	3																			
高温负荷特性 Load life	<p>在+105°C 环境中施加额定工作电压和最大允许纹波电流 4000~10000 小时后,电容器的性能符合下面要求: After application of rated working voltage with max permissible ripple current specified at +105 °C for 4000~10000 hours, capacitors meet the characteristics requirements measured at +20°C listed at below:</p> <p>1、电容量变化率:±25%初始测量值以内 Capacitance change : ±25% initial measured value</p> <p>2、漏电流: ≤初始规定值 Leakage current: ≤initial specified value</p> <p>3、损耗角正切值≤200%倍初始规定值 Dissipation factor: ≤200% initial specified value</p>																									
			<table border="1"> <thead> <tr> <th rowspan="2">外径 Case Dia</th> <th colspan="2">时间(hrs) Life Time</th> </tr> <tr> <th>6.3~10WV</th> <th>16~100WV</th> </tr> </thead> <tbody> <tr> <td>ΦD≤8</td> <td>4000</td> <td>5000</td> </tr> <tr> <td>ΦD=10</td> <td>6000</td> <td>7000</td> </tr> <tr> <td>ΦD≥12.5</td> <td>8000</td> <td>10000</td> </tr> </tbody> </table>		外径 Case Dia	时间(hrs) Life Time		6.3~10WV	16~100WV	ΦD≤8	4000	5000	ΦD=10	6000	7000	ΦD≥12.5	8000	10000								
外径 Case Dia	时间(hrs) Life Time																									
	6.3~10WV	16~100WV																								
ΦD≤8	4000	5000																								
ΦD=10	6000	7000																								
ΦD≥12.5	8000	10000																								
高温贮存特性 Shelf life	<p>在+105°C环境无负荷放置 1000 小时后, 电容器的性能符合下面要求 After leaving capacitors under no load at +105°C for 1000 hours, capacitors meet the characteristics listed as below:</p> <p>1、电容量变化率:±25%初始测量值以内 Capacitance change : ±25% initial measured value</p> <p>2、漏电流: ≤200%初始规定值 Leakage current: ≤200% initial specified value</p> <p>3、损耗角正切值≤200%倍初始规定值 Dissipation factor: ≤200% initial specified value</p>																									

4. 产品结构 PRODUCT STRUCTURE (mm)

4.1 外形尺寸 SHAPE AND DIMENSIONS

β	±0.5			±1.0				
ΦD	5	6.3	8	10	12.5	16	18	22
F±0.5	2.0	2.5	3.5	5.0		7.5		10.0
Φd±0.1	0.5		0.6			0.8		
L	7,11,12	12,16,20	12,16,20,25,30	16,20,25,30,35	16,20,25,30,35	20,25,30,35,40	40	
	L≤16: L±1.5; L>16: L±2.0							

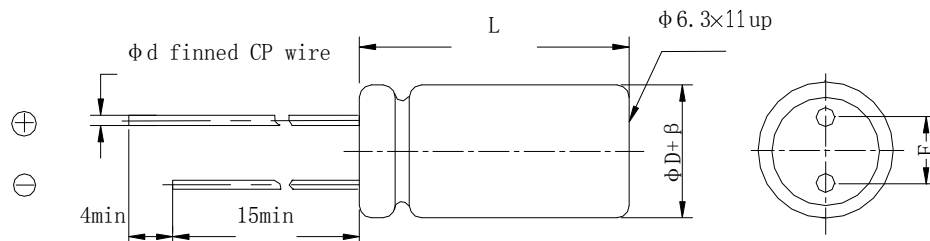



4. 1. 1 内部构造图及构成材料 INTERNAL CONSTRUCTION AND COMPONENTS

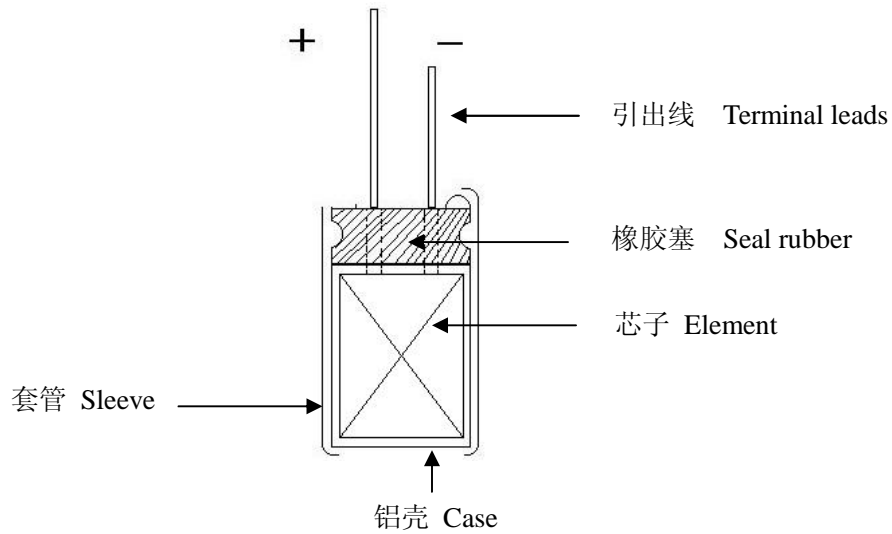

芯子分解图 Dicomposing figure of clement

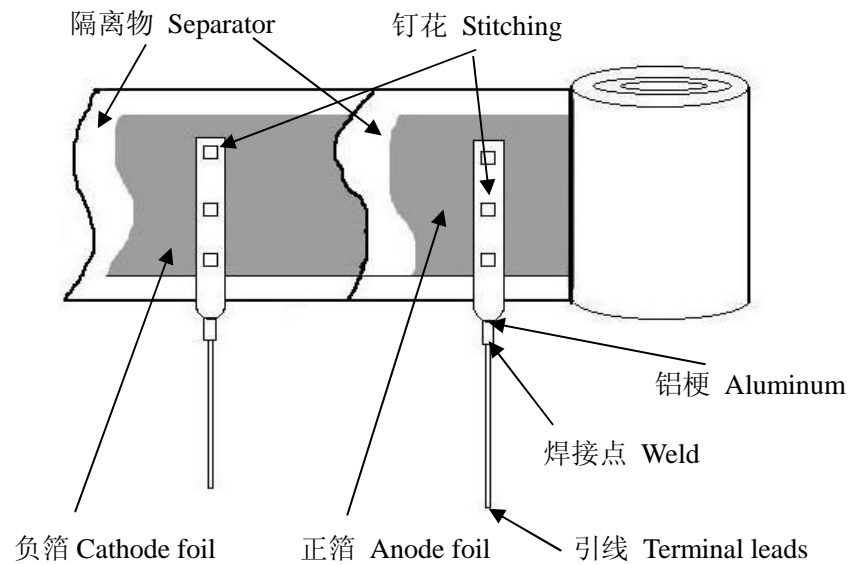

序号 Components	材料.规格.处理 Materials.Finish/Specification	序号 Components	材料.规格.处理 Materials.Finish/Specification
1 铝壳 Case	铝 Aluminum	5 隔离物 Separator	电解纸 Paper
2 套管 Sleeve	胶管 Sleeve	6 正箔 Anode foil	高纯铝 Fine Aluminum
3 封口塞 Seal	IIR 胶粒 IIR rubber	7 负箔 Cathode foil	铝 Aluminum
4 引线 Terminal lead	CP 线(铁+锡) CP wire (Fe+Sn)	8 电解液 Electrolyte	有机溶剂 Organic Solvent etc



4.2 引线编带 TAPING METHOD (mm)

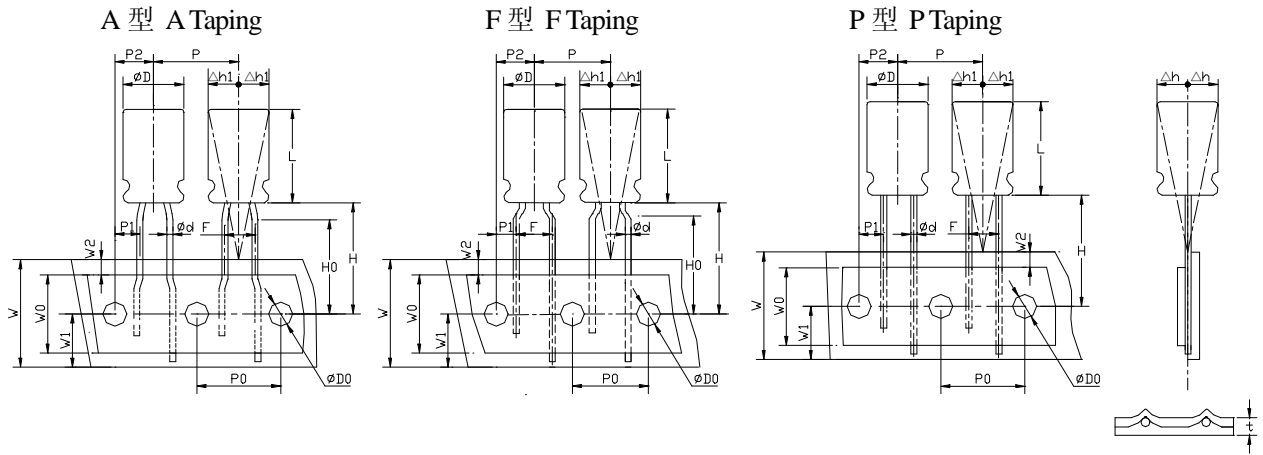

单位: mm

外径 Case Dia 项目及误差 Item Tolerance	Φ4	Φ5	Φ6.3	Φ4	Φ5	Φ6.3	Φ8	Φ8	Φ10	Φ12~Φ13	Φ16~Φ18	
L+2max	5~16		5~16		7~20		7~20	9~20	16-25	16-25		
代码 Taping code	A			F				P				
Φd±0.05	0.45~0.50		0.45~0.50		0.60		0.60	0.60	0.60	0.8		
P±1.0	12.70		12.70				12.70		15.0	30.0		
P ₀ ±0.2	12.70		12.70				12.70		15.0	15.0		
P ₁ ±0.5	5.10		3.85				4.60	3.85	5.00	3.75		
P ₂ ±0.5	6.35		6.35				6.35		7.50			
F± ^{0.5} _{0.2}	2.50		5.00				3.50	5.00±0.5		7.5±0.5		
H±0.5	18.5											
H ₀ ±0.5	16.5	-	16.5									
W±0.3	18.00											
W ₀ min	10.00											
W ₁ ±0.5	9.00											
W ₂ max	3.00											
ΦD ₀ ±0.2	4.00											
Δh max	0.50											
Δh ₁ max	0.50											
t±0.2	0.60											

5. 纹波电流频率因子 RIPPLE CURRENT FREQUENCY COEFFICIENT

Freq (Hz)	50 (60)	100 (120)	1K	10K	≥100K
6.8~33	0.30	0.42	0.70	0.90	1.00
39~270	0.35	0.50	0.73	0.92	1.00
330~680	0.40	0.55	0.77	0.94	1.00
820~1800	0.45	0.60	0.80	0.96	1.00
2200~18000	0.50	0.70	0.85	0.98	1.00



6. 尺寸表、允许纹波电流 DIMENSIONS AND RIPPLE CURRENT (LY)

WV/V Cap/μF	6.3(LA)			10(LB)			16(LC)			25(LD)			35(LE)		
	(1)	(2)	(3)	(1)	(2)	(3)	(1)	(2)	(3)	(1)	(2)	(3)	(1)	(2)	(3)
6.8(6R8)													5×11	2.5	55
10(100)													5×11	2.0	100
15(150)															
22(220)															
33(330)													5×11	0.58	210
47(470)										5×11	0.58	210	5×11	0.75	200
56(560)							5×11	0.58	210	5×11	0.58	212	6.3×12	0.25	340
68(680)													6.3×12	0.45	280
82(820)															
100(101)				5×11 6.3×12	0.60 2.0	180 210	6.3×12	0.25	320	6.3×12	0.25	330	6.3×12 8×12	0.2 0.18	450 500
120(121)							6.3×12	0.23	350						
150(151)	5×11	0.58	200				6.3×12	0.58	210	6.3×12	0.35	400	8×12	0.13	640
180(181)													8×16	0.11	700
220(221)				5×11 6.3×12	0.60 0.26	220 330	6.3×12	0.19	320	8×12 10×12	0.13 0.13	640 700	5×11 8×12 8×16 10×12	0.095 0.095 0.087 0.080	800 800 840 865
270(271)										8×16	0.11	700	8×20	0.069	1050
330(331)	6.3×12	0.25	330	6.3×12	0.20	450	8×12	0.13	640	8×12 8×16 10×12	0.11 0.087 0.080	750 840 865	8×16 10×12 10×16	0.07 0.07 0.060	1120 1120 1210
390(391)													8×20	0.075	1200
470(471)	6.3×12	0.22	350	6.3×12 8×12	0.18 0.13	500 640	8×12 8×16 10×12	0.095 0.087 0.080	800 840 865	8×16 8×20 10×16	0.10 0.069 0.060	1000 1050 1210	10×16 10×20 12.5×16 12.5×20	0.06 0.046 0.049 0.049	1300 1400 1450 1450
560(561)	8×12	0.15	580	8×16	0.11	700	8×14 8×16	0.095 0.085	840 860	10×16	0.058	1280	10×20	0.042	1650
680(681)	8×12	0.13	640	8×16 10×12	0.087 0.080	840 865	8×16 8×20 10×12 10×16	0.08 0.069 0.069 0.060	1050 1050 1050 1210	10×20 12.5×16	0.046 0.049	1400 1450	10×20 10×30 12.5×20	0.085 0.031 0.035	1800 1910 1900
820(821)	10×12	0.080	865	10×12	0.08	950	10×16	0.06	1250	10×20	0.042	1650	12.5×20	0.035	1900
1000(102)	8×16	0.087	840	8×20 10×12 10×16 10×20	0.069 0.09 0.060 0.06	1050 1050 1210 1210	10×16 10×20 12.5×16	0.06 0.046 0.049	1300 1400 1450	10×30 12.5×20	0.031 0.035	1910 1900	12.5×20 12.5×25	0.035 0.027	2150 2230
1200(122)	8×20 10×16	0.069 0.060	1050 1210	10×20	0.046	1400	10×20	0.042	1650	16×20	0.043	2210	12.5×30	0.024	2650
1500(152)	10×20	0.046	1400	10×20 12.5×16	0.069 0.060	1650 1210	10×20 10×30 12.5×20	0.055 0.031 0.035	1910 1910 1900	12.5×20 12.5×25	0.035 0.02	2200 2230	12.5×35	0.020	2880
1800(182)	12.5×16	0.049	1450	12.5×20	0.033	1650	12.5×25	0.03	2100	12.5×30	0.024	2650	16×25	0.021	2930
2200(222)	10×20	0.042	1650	12.5×20	0.035	1900	12.5×20 12.5×25	0.055 0.027	2100 2230	12.5×25 12.5×35	0.05 0.020	2700 2880	16×25 16×30	0.035 0.017	3200 3450
2700(272)	10×30	0.031	1910	18×20	0.043	2210	12.5×30	0.024	2650	16×25	0.021	2930	16×35	0.015	3610
3300(332)	12.5×20	0.035	1900	12.5×25	0.027	2230	12.5×25 12.5×35	0.05 0.020	2880	16×30	0.017	3650	18×25 18×30 18×35	0.042 0.042 0.014	4000 4000 4220
3900(392)	12.5×25	0.027	2230	12.5×30	0.024	2650	16×25	0.021	2930	16×35	0.015	3610	18×40	0.012	4280
4700(472)	12.5×30	0.024	2650	12.5×35	0.020	2880	16×30	0.017	3450	18×35	0.014	4220	18×45	0.016	3820
5600(562)	12.5×35 16×20	0.020 0.027	2880 2530	16×35	0.021	2930	16×35	0.015	3610	18×40	0.012	4280			
6800(682)	16×25	0.021	2930	16×30	0.017	3450	18×35	0.014	4080						
8200(822)	16×30	0.017	3450	16×35	0.015	3610	18×35	0.014	4220						
10000(103)	16×35	0.015	3610	18×35	0.014	4220	18×40	0.012	4280						
12000(123)	18×30	0.015	4170	18×40	0.012	4280									
15000(153)	18×35	0.014	4220												
18000(183)	18×40	0.012	4280												



WV/V Cap/μF	50(LF)			63(LG)			80(LH)			100(MA)			
	(1)	(2)	(3)	(1)	(2)	(3)	(1)	(2)	(3)	(1)	(2)	(3)	
1.0(1R0)	5×11	5.0	22										
2.2(2R2)	5×11	2.5	42							5×11	3.5	60	
3.3(3R3)	5×11	2.3	47										
4.7(4R7)	5×11	2.0	110							5×11	2.5	55	
	6.3×12	0.85	80										
6.8(6R8)	5×11	1.9	88							5×11	1.9	92	
10(100)	5×11	1.4	124	5×11	1.0	80				6.3×12	1.5	200	
	6.3×12	0.45	150										
15(150)				5×11	1.8	62				6.3×12	1.0	126	
22(220)	5×11	0.70	210							6.3×12	0.70	180	
	6.3×12	0.75	185							8×12	1.3	250	
27(270)										8×12	0.45	250	
33(330)	6.3×12	0.48	230	6.3×12	0.45	240	8×12	0.55	250	8×12 8×16	0.45 0.80	250 350	
39(390)										8×16	0.40	300	
47(470)	6.3×12	0.35	380	6.3×12	1.1	135				8×12,14	0.38	280	
	8×12	0.45	300	6.3×15	0.55	200				8×16	0.35	300	
										10×12	0.34	325	
56(560)	6.3×12	0.35	280	8×12	0.50	260	8×12	0.055	250	8×16 8×20	0.28 0.26	380 408	
68(680)	8×12	0.23	350	8×12	0.45	280	8×12	0.45	280	8×16	0.28	300	
				8×20						0.35			400
				10×16						0.25			400
82(820)				8×16 10×12	0.36	335	10×12	0.17	450	10×20	0.17	518	
100(101)	8×12	0.17	555	8×12,14	0.35	330	8×16	0.40	500	10×16	0.17	555	
	8×16	0.13	500	8×16	0.3	350	10×16	0.13	580	10×20	0.16	595	
				10×12	0.3	350				12.5×25	0.55	500	
				10×16	0.33	350							
120(121)	8×16	0.12	730	8×14	0.28	408	8×20	0.26	400	10×25 12.5×20	0.13	765	
150(151)	8×12	0.15	700	8×20	0.25	400				10×20	0.15	580	
	10×12	0.12	760							16×16	0.11	895	
180(181)	8×20	0.091 0.12	910	10×16	0.18	518	10×20	0.10	750	12.5×25	0.096	875	
	10×12		900	10×20	0.17	518	12.5×16	0.25	650				
				12.5×16	0.18	527							
220(221)	8×14	0.15	800	10×12	0.16	595	12.5×20	0.18	900	10×40	0.08	1010	
	8×16	0.095	900	10×16	0.16	595				12.5×20	0.080	900	
	8×20	0.09	950	10×20	0.13	700				12.5×30	0.080	1010	
	10×14	0.095	950	10×25	0.23	550							
	10×16	0.084	1050										
270(271)	10×20	0.060	1220	10×20	0.13	700	12.5×16	0.13	760	12.5×35	0.070	1140	
				12.5×16	0.15	700	12.5×20	0.12	765				
				12.5×20	0.13	765							
330(331)	10×16	0.08	1300	10×20	0.25	750	12.5×20	0.072	1100	18×20	0.072	1300	
	10×20,25	0.055	1440	10×25	0.13	750	12.5×25	0.09	1100				
	12.5×16	0.055	1440	12.5×16	0.11	765							
				12.5×20,25	0.096	875							
390(391)				12.5×20	0.10	1500	12.5×16 12.5×20	0.095 0.09	750 1200				
470(471)	10×25	0.055	1690	12.5×20 12.5×30	0.09 0.080	780 1010	16×20 16×25	0.075 0.065	1400 1300	16×30	0.040 0.040 0.045	1900 1900 1900	
	10×30	0.043	1690										
	12.5×16	0.08	1500										
	12.5×20	0.045	1660										
	16×16	0.065	1660										



560(561)	12.5×20 12.5×25	0.07 0.034	1950	12.5×20 12.5×35 16×20 16×25	0.09 0.065 0.065 0.062	1000 2000 1350 1350				18×35	0.036	2130
680(681)	10×30 12.5×30	0.045 0.030	1950 2310	16×20 16×25 18×20	0.072	1300				18×35	0.036	1890
820(821)	12.5×25 12.5×35 16×20	0.03 0.025 0.035	2300 2570 2570	12.5×35 12.5×40 16×30	0.07 0.055 0.049	1500 1600 1650				18×40	0.032	2470
1000(102)	16×25	0.025	2555	16×25 16×35	0.05 0.040	1900						
1200(122)	16×30	0.022	3010	18×35	0.036	1890						
1500(152)	16×35	0.019	3150	18×40	0.032	2470						
1800(182)	18×30	0.021	3635									
2200(222)	18×35	0.017	3680	18×40	0.038	3860						
2700(272)	18×40	0.014	3800									

(1) 外形尺寸 Case Size D×L(mm)

(2) 100KHz 阻抗值 Impedance at 100KHz +20°C (Ω)

(3) 最大允许纹波电流 Max allowable ripple current (mA rms, +105°C,100KHz)

6.1 客户料号与风华物料对照表 Customer P/N and Fenghua P/N collate list

客户 P / N	风华 P / N
--	8221LEM0812LYN0110
--	8102LDM1020LYN0110



7. 包装 PACKING

7.1 包装标签 PACKING LABEL

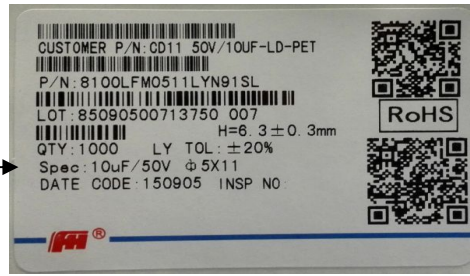

规格、尺寸 Specification and dimensions

批号的填写 LOT:

1	2	3	4	5	6	7	8	9	10	11	12	13	14
---	---	---	---	---	---	---	---	---	----	----	----	----	----

类别 年份 月份 日期 区别号

流传单号码

Sort Year Month Date Discriminate mark

Sequence number

7.2 编带产品按下图包装

Taped capacitors are packed into carton, according to the following drawing.

ΦD	Qty. (Pcs)	L(电容高度)≤22mm	L(电容高度)=25±2mm
		L×W×H(mm)	L×W×H(mm)
Φ5	2000	328X235X50	328X235X57
Φ6.3	1500		
Φ8	1000		
Φ10	600		
Φ12.5	400		
Φ16	250		
Φ18	200		

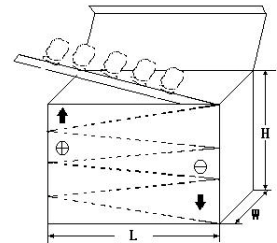

7.3 散包装按下图包装方式

Bulk packing capacitors are packed into PVC bag, inner box and carton according to the following drawings.

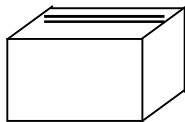

内盒
inner box



外箱
carton

7.4 散装、编带品外包装箱不干胶标签，实用尺寸为 167.5mmX97.5mm。

The dimension of the label on the carton is 167.5mmX97.5mm

		广东风华高新科技股份有限公司 FENGHUA ADVANCED TECHNOLOGY HOLDING CO., LTD			
装箱清单号: LH201605100007		箱号: 4/5			
客户名称	业务员	订单号: SA20160428170D 业务部: 华北业务部		净重Kg: 11.5 毛重Kg: 4.3	
序号	型号规格	客户料号	客户PO	数量 (件数)	备注
1	8220MFMA20RGN91FP 22uF/350V φ12.5X20	PBEH-202203100374	868209642	3.2	
合计				3.2	
日期: 16/05/10					

8. 贮存方法 STORAGE METHODS

保存期限: 1年, 超一年后, 需对产品重新加工作电压老练后才使用。

如果没有其他规定, 标准的测试、检验环境条件如下所示:

环境温度: 5至35℃; 相对湿度: 45至85%; 大气压力: 86kpa至106kpa。

如果对测试结果有异议, 可以在以下条件测试:

环境温度: 20±2℃; 相对湿度: 60至70%; 大气压力: 86kpa至106kpa。



Storage life: 1 year, after a year, the product need to be recharged before use.

Unless otherwise specified, the standard range of atmospheric conditions for making measurements and tests are as follows.

Ambient temperature: 5 to 35°C Relative humidity: 45 to 85% Air pressure: 86kpa to 106kpa.

If there may be doubt on the results, measurements shall be made within the following limits.

Ambient temperature: 20±2°C Relative humidity: 60 to 70% Air pressure: 86kpa to 106kpa.

9. 其它说明 OTHERS

9.1 铝电解电容器使用注意事项 Important information on the application of aluminium electrolytic capacitors

(1).直流铝电解电容器应按正确的极性使用 DC electrolytic capacitors are polarized

当直流铝电解电容器被反极性接入电路时,电容器会导致电子线路短路,由此产生的电流会引致电容器损坏。若电路中有可能在负引线施加正极电压,请选用无极性产品。

When reverse voltage is applied on DC electrolytic capacitor, the capacitor will become short-circuited please use non-polarized capacitors in the circuit or the capacitor will be damage due to abnormal current flows through the capacitors since the circuit where the positive voltage may be applied to the cathode terminal.

(2).在额定工作电压以下作用 Use capacitor within rated voltage

当电容器上所施加电压高于额定工作电压时,电容器的漏电流将上升,其电气特性将在短时期内劣化直至损坏。请注意电压峰值勿超出额定工作电压。

When capacitor is used at higher voltage than the rated voltage, leakage current increases, characteristics drastically deteriorate and damage in a short period may occur as a result. Please take extra caution that the peak voltage should not exceed the rated voltage.

(3).作快速充放电使用 Charge and discharge application.

当常规电容器被用作快速充电用途。其使用寿命可能会因为容量下降,温度急剧上升等而缩减

When aluminum electrolytic capacitors for general purpose are employed in rapid charge and discharge application, its life may be shorted by capacitance decreasing, heat rising, etc.

(4).电容器贮存 Store the capacitor.

当铝电解电容器作了长期贮存后,其漏电流通常升高,贮存温度愈高,漏电流上升愈快。因此应注意贮存环境的选择,在电容器上施加电压后,漏电流值将不断下降,在铝电解电容器的漏电流值上升对电路有不良影响的,请在使用前充电处理。

Increased leakage current is common in aluminum capacitors which have been stored for long period of time. The Higher the storage temperature, the higher the leakage current increase, therefore please take precautions concerning the storage location. The leakage current decreases gradually as voltage is applied to the capacitor. In cases where increased leakage current causes problems in the circuit, apply voltage (aging) before using.

(5).施加纹波电流应小于额定值 Ripple current applied to capacitor should not exceed the rated value.

施加纹波电流超过额定值后,会导致电容器体过热,容量下降,寿命缩短。所施加纹波电压的峰值应小于额定工作电压。

Excessive heat will reduce capacitance and result in shortened life of capacitor if ripple currents exceeding the specified rated value are applied. The peak value of the ripple voltage should be less than the rated voltage.

(6).使用环境温度 Ambient temperature.

铝电解电容器的使用寿命会受到环境温度的影响。据科学统计,使用环境温度下降 10°C 其使用寿命增加 1 倍。

Its ambient temperature closely affects the life of an aluminum electrolytic capacitor. It is generally stated, that life doubles for each 10°C decrease in temperature.

(7).引出线强度 Lead stress

当拉力施加到电容器引出线,该拉力将作用于电容器内部,这将导致电容器内部短路,开路或漏电流上升。在电容器焊装到电路板,请勿强烈摇动电容器。

When a strong force is applied to the lead wires or terminals, stress is put on the internal connections. This may result in short circuit, open circuit or increased leakage current. It is not advisable to bend or handle a capacitor after it has been soldered to the PCB board.

(8).焊接过程耐热性 Heat resistance at the soldering process

铝电解电容器装至电路板进行浸焊或波峰焊时,其塑料套管可能因焊接时间过长、温度过高而发生破裂或二次收缩。

In the dip soldering process of PCB board with aluminum electrolytic capacitors mounted, secondary shrinkage or crack of PVC sleeve may be observed when solder temperature is too high or dipping time is too long.

(9).电路板的安装孔距及安装位置 Hole pitch and position of PCB board.

电路板安装孔的设计应与产品说明书的引线脚距相一致,如果将电容器强行插入孔距不配套的电路板,那么会有应力作用于引出线,这将导致短路或漏电流上升。

PCB board must be designed so its hole coincides with the lead pitch (lead spacing) of the capacitor specified by the catalog or specifications. When a capacitor is forcibly inserted into an unmatched hole, a stress is put on the leads. This could result in a short circuit or increased leakage current.

9.2 本产品不含铅、镉等元素 This product does not include Plumbum or Cadmium.